



**CIRCLE
S
PRODUCTS, INC.**

TECHNICAL BULLETIN

MODEL: Liquid Level Gauges

TB No. S5300

Date 3-01

Quality design which conform to requirements of ASME Boiler Code . Upper and lower valves are equipped with corrosion resistant ball checks which prevent lose of vessel contents in event of glass breakage.

**No. 1
SELF CLEANING TYPE**

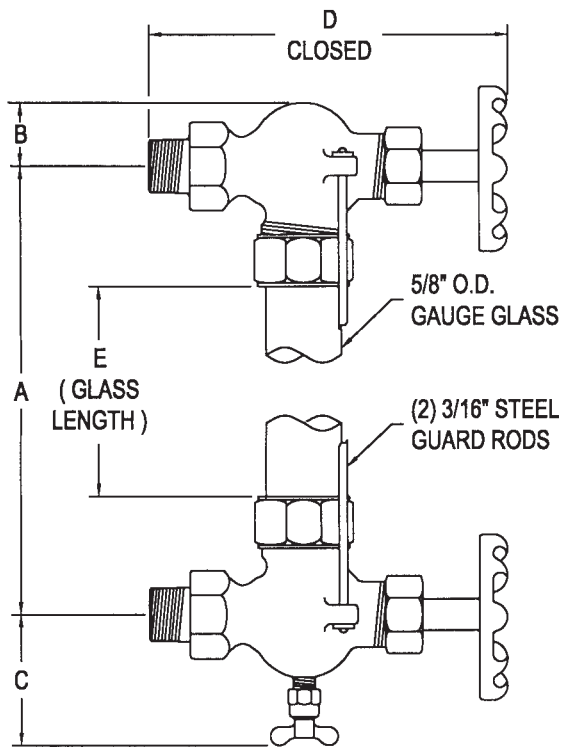

**No. 19-G4
BALL CHECK TYPE**

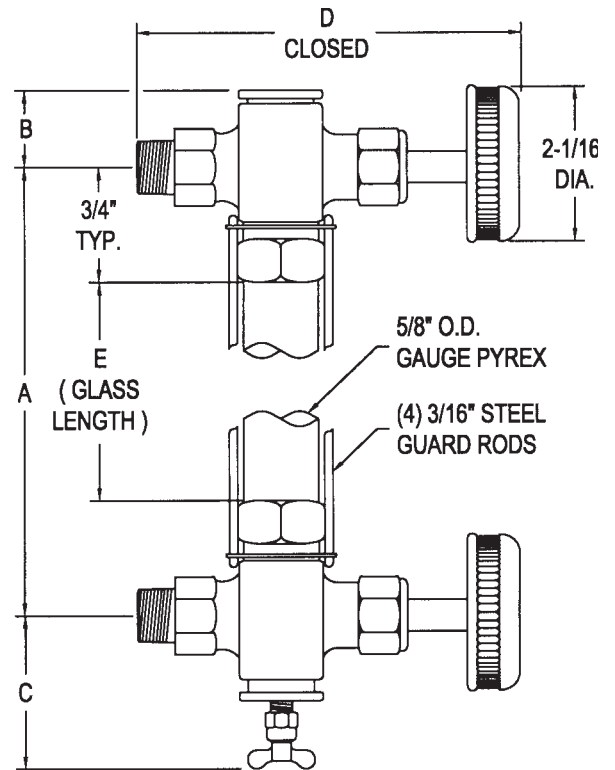

DIMENSIONS AND DATA

	#1	19-G4
Gauge No.	#1	19-G4
NPT Vessel Connection	1/2"	1/2"
Dimension A	(Specify)	(Specify)
Dimension B	1 1/16"	7/8"
Dimension C	1 3/4"	1 3/8"
Dimension D Closed	4 9/16"	4 7/8"
Dimension E	A - 1 1/2"	A - 1 1/2"
Weight	2 lbs.	4.5 lbs.
Working Rating (PSIG)	0 - 200	0 - 400