



CIRCLE

PRODUCTS, INC.

TECHNICAL BULLETIN

TYPE: Horizontal flow installations only
MODEL: Dry-Flo™ TS Moisture Separator
 TB No. S3850 Date 1-99

Gas, laden with moisture, enters the inlet of the separator where a deflector plate directs the flow in a downward centrifugal motion. The entrained moisture is then separated out of the flow by a reduction in velocity. The separated liquid is sent to the outer walls of the separator and falls below the re-entrainment breaker plate where it is prevented for re-entering the flow stream. The addition of a sump area will allow for a liquid hold-up capacity. A dry, clean flow then results, exiting upward through the outlet of the separator.

With correct sizing and proper drainage, these separators are designed to eliminate 99% of all entrained liquids and particles that are 10 microns and larger in size.

The Model "TS" Separators can be fabricated from carbon steel or stainless steel and are manufactured in accordance with the ASME Code Section VIII, Division I.

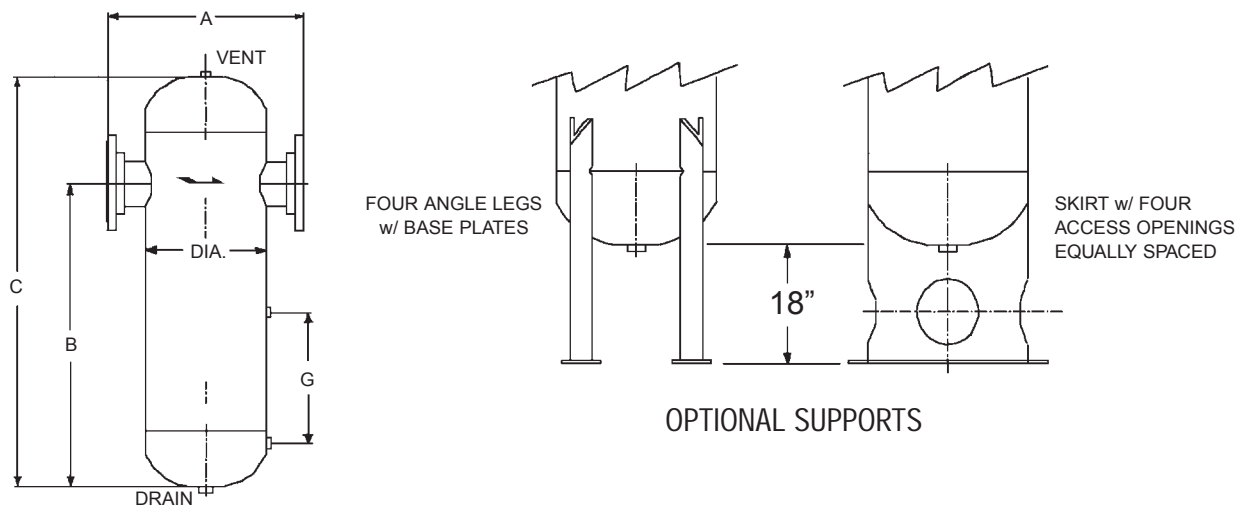

DIMENSIONS AND WEIGHTS

PIPE SIZE	FLANGED A	DIA.	B	C	G	NPT DRAIN	150#	300#	LIQUID HOLD-UP CAPACITY (CUBIC FEET)
							FLANGED	FLANGED	
							DESIGN 150 PSIG @ 450° F	DESIGN 500 PSIG @ 650° F	
						STD	WEIGHT	WEIGHT	
1"	10 1/2"	5 9/16"	22"	28"		1"	47	49	0.19
1 1/4"	10 1/2"	5 9/16"	22"	28"		1"	50	52	0.19
1 1/2"	11 1/2"	6 5/8"	24"	30"		1"	69	75	0.2
2"	11 1/2"	6 5/8"	24"	30"		1"	74	78	0.2
2 1/2"	16"	8 5/8"	27"	35"		1"	122	132	0.39
3"	18"	10 3/4"	30"	38"	9 1/8"	1"	170	180	0.66
4"	20"	12 3/4"	36"	45"	10 1/4"	1 1/2"	225	250	1.07
5"	22"	14"	40"	50"	10 1/4"	1 1/2"	265	335	1.35
6"	24"	16"	55"	66"	10 1/4"	1 1/2"	400	435	3.03
8"	28"	18"	62"	75"	11 7/8"	2"	545	700	3.83
10"	34"	24"	76"	91"	11 7/8"	2"	800	1355	6.94
12"	38"	28"	82"	99"	11 7/8"	2 1/2"	1090	1735	11.74
14"	42"	32"	89"	108"	12 5/8"	2 1/2"	1335	2535	16.81
16"	47"	36"	98"	119"	12 5/8"	3"	1850	3200	20.22
18"	54"	42"	108"	132"	12 5/8"	3"	2600	5025	22.99
20"	62"	48"	118"	145"	15"	3"	3275	6480	26.47
22"	64"	48"	121"	149"	15"	3"	3450	7000	26.47
24"	70"	54"	129"	158"	15"	4" *	4940	9020	32.64

* Flanged Drain