



**CIRCLE  
S  
PRODUCTS, INC.**

**TECHNICAL BULLETIN**

**MODEL: "FL5" FLASH TANK**

TB No. S5000

Date 1-01

**SAMPLE SPECIFICATION**

Flash Recovery Vessel shall be mild steel construction ASME Code Stamped for 150 psig steam service with ANSI 150# RF flanges. Connections for a pressure gauge and a Safety Relief Valve shall be provided in the shell.

**INSTALLATION**

The vessel should be installed with the flash steam outlet at the top as shown. Each size vessel incorporates a 1/2" NPT connection for the fitting of a pressure gauge. If a Safety Relief Valve is required, it should be fitted in the NPT connection provide in the side of the shell. For drainage, a properly sized float type steam trap must be connected to the condensate outlet at the bottom of the vessel.

**STANDARDS**

These vessels are designed in accordance with ASME Code Section VIII, Div. 1 and can be ASME Code Stamped for 150 psig steam service.

**HOW TO SIZE**

Fig. 1 shows the proportions by weight of flash steam formed from condensate with various pressure drops. From Fig. 1, find the weight of flash per unit weight of condensate. Multiply this by the maximum condensing rate to get the maximum weight of flash steam expected from the flash vessel. Select the appropriate size flash vessel from Fig. 2 by finding the area within which both the condensate rate and the flash steam weight fit.

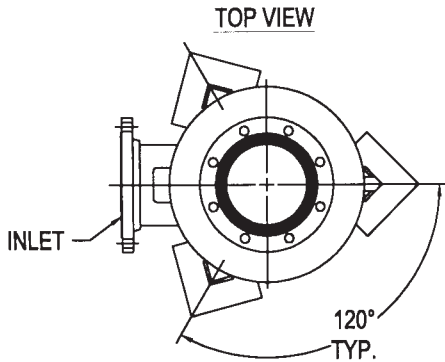

DIMENSIONS									
SIZE	INLET/OUTLET	A	B	C	D	E	F	G	H
4"	1 1/2"	6"	36"	45"	4 1/2"	24"	8"	3/4"	3/4"
6"	2 1/2"	7"	38 1/2"	47"	6 5/8"	22 1/2"	9"	3/4"	1 1/2"
8"	4"	8"	39 1/2"	48"	8 5/8"	25 7/8"	9 1/2"	3/4"	2"
12"	5"	10"	41 3/8"	49 1/2"	12 3/4"	26 7/8"	11 1/2"	1 1/2"	3"
16"	6"	12"	49 3/4"	58"	16"	32"	12 1/2"	2"	3"

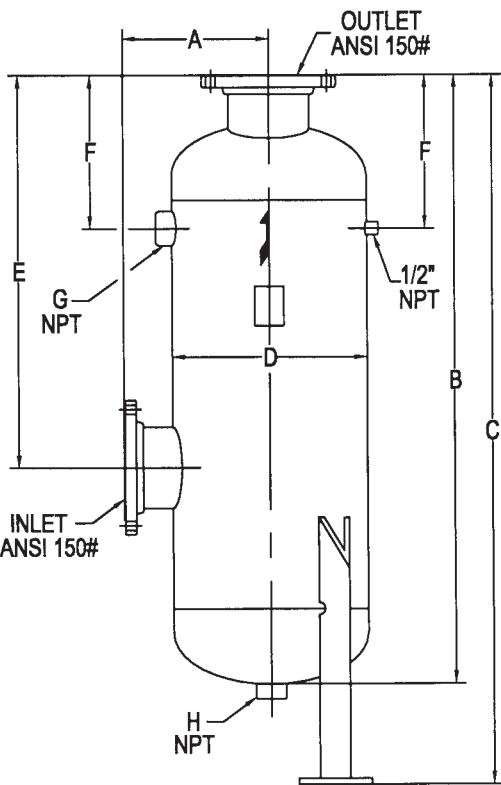

**FIG. 1  
PROPORTION OF  
FLASH STEAM**

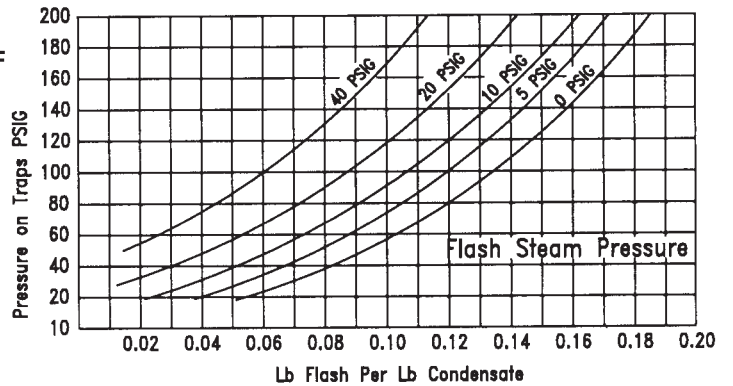

**FIG. 2  
RECOVERY  
VESSEL  
CAPACITIES**

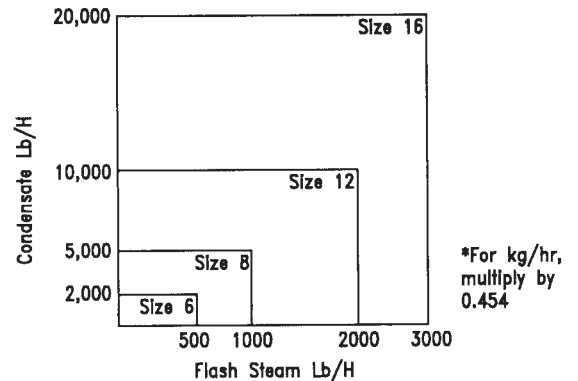

\*For kg/hr, multiply by 0.454