



CIRCLE
S
 PRODUCTS, INC.

TECHNICAL BULLETIN

TYPE: Horizontal

MODEL: Dry-Flo™ CS Moisture Separator

TB No. S3875

Date 1-99

- Dry-Flo model CS separators are cast iron which meets ASTM-A-278 Class 35 standards.
- All pressure parts are designed and built to meet ASME Code, Section VIII for unfired pressure vessels.
- Removes over 99% of all particulates in excess of 10 microns in size over a wide range of flow rates.
- Compact trap design features stainless steel moving parts and permits easy access for service. Manual draining is also available.
- Unit is lightweight — can be supported by just the piping.
- Optional heating element prevents freezing.

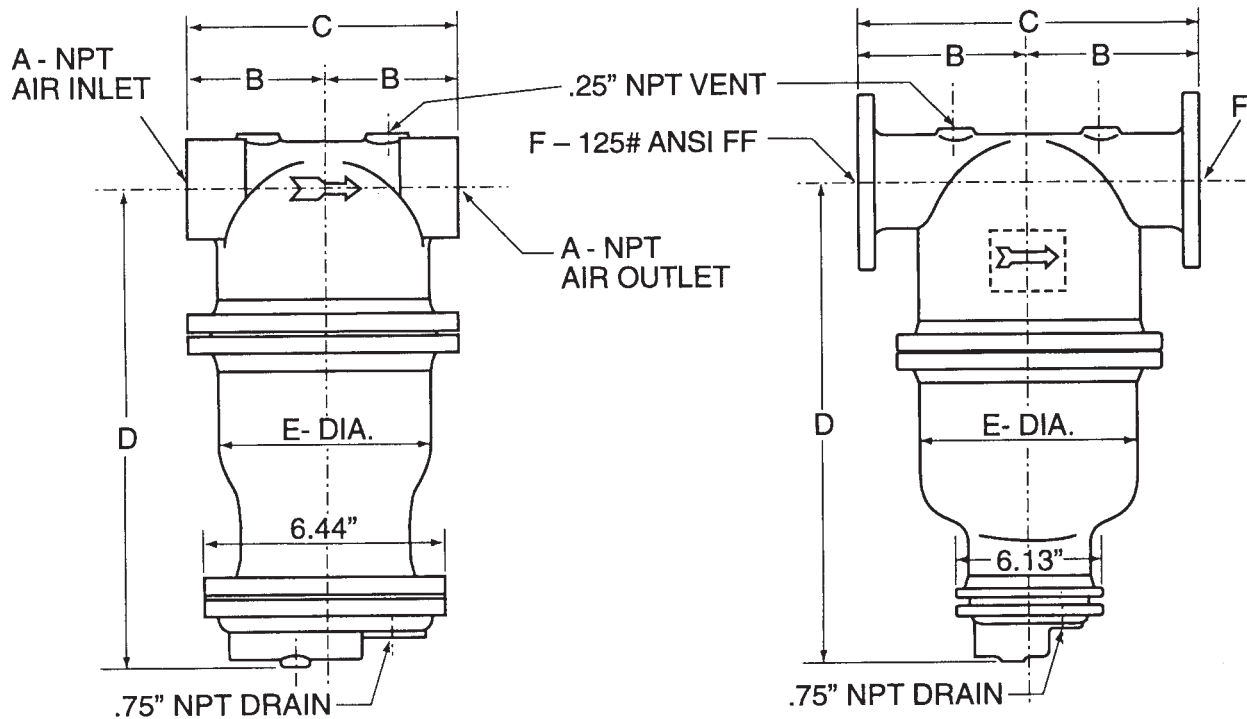

DESIGN: 160 PSIG @ 300° F (Non Code)
 DESIGN: 250 PSIG @ 250° F (Non Code)

DESIGN: 150 PSIG @ 450° F (Non Code)

DIMENSIONS AND WEIGHTS

A	B	C	D	E	F	WEIGHT
.50"	2.75"	5.50"	11.88"	4.13"	-	22
.75"	2.75"	5.50"	11.88"	4.13"	-	22
1.00"	3.00"	6.00"	13.63"	5.25"	-	27
1.25"	3.00"	6.00"	13.63"	5.25"	-	27
1.50"	3.75"	7.50"	13.63"	5.88"	-	34
2.00"	4.06"	8.13"	15.38"	6.63"	-	44
2.50"	4.68"	9.38"	19.38"	7.75"	-	68
3.00"	5.50"	11.00"	20.88"	9.13"	-	97
-	7.13"	14.25"	20.38"	9.00"	3.00"	105
-	7.94"	15.88"	23.50"	11.25"	4.00"	142